



PARTICLE SIZE AND SHAPE ANALYZER

CAMSIZER 3D

The CAMSIZER 3D particle analyzer combines all the advantages of dynamic image analysis (ISO 13322-2) in a completely redesigned measuring system, setting new standards in the characterization of bulk solids.

Unique 3D Analysis: Thanks to the extended field of view and long drop distance, each particle is analyzed up to 30 times and in different orientations, making the actual, three-dimensional particle morphology accessible for analysis. The evaluation of the “3D tracks” also provides much more meaningful shape analysis than ever before.

Proven 2-Camera System: The new ZOOM camera inside the CAMSIZER 3D (9 MPx) allows for the evaluation of fine particles with great accuracy. In combination with the BASIC camera (5 Mpx), this enables a wide measuring range from 20 µm to 30 mm. CAMSIZER 3D is the first choice for the analysis of dry, free-flowing bulk solids in both quality control and for research applications.



PARTICLE SIZE AND SHAPE ANALYZER
CAMSIZER 3D

THE MOST POWERFUL DYNAMIC IMAGE ANALYSIS

- | Patented 3D analysis with "Particle Tracking"
- | Up to 30 images of every particle
- | Particle size and shape analysis from 20 μm to 30 mm without hardware adjustment
- | Short measuring time of 2 to 5 minutes
- | High sample throughput
- | 100% detection of oversize particles
- | Excellent compatibility to sieve analysis
- | Excellent reproducibility
- | Evaluation of > 250 images / s in real time (in 3D mode)
- | Powerful, long-life LED light source
- | Maintenance-free

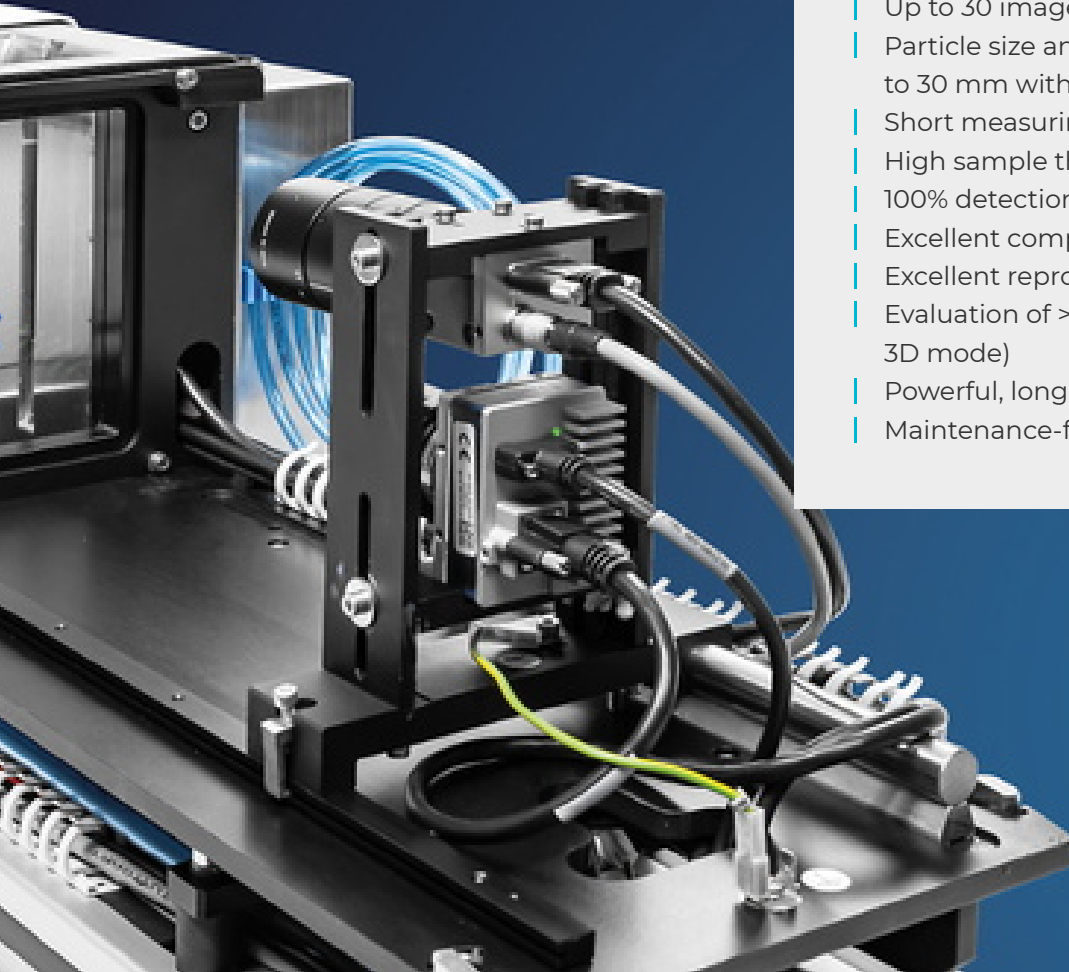

UNIQUE & PATENTED

3D PARTICLE TRACKING TECHNOLOGY

The CAMSIZER 3D utilizes a funnel, vibrating feed chute, LED strobe backlighting, powerful high-speed cameras, and sophisticated software to perform the measurements.

The particles travel down the vibrating feeder and fall into the sensing zone, creating a tumbling motion as they fall. The CAMSIZER software tracks each particle as it passes between light source and cameras, taking up to 250 images per second. As the particle is tracked, multiple images are recorded, measuring length, width, thickness, perimeter, area and various shape descriptors. The software automatically aligns the images for viewing, with up to 30 images per particle. This creates a “particle track”, a sequence of images of the same particle in different orientations. From this, distributions can be calculated, based on one or more size or shape parameters. Filters can be applied to isolate groups of particles of particular interest for more targeted analysis.



[Click to view video](#)

In the particle track, the software determines the width and the length of each particle projection:

- | the largest value of all length measurements within a particle track is the “3D length” of the particle
- | the largest value of all width measurements within a particle track is the “3D width” of the particle
- | the smallest value of all width measurements within a particle track is the “3D thickness” of the particle

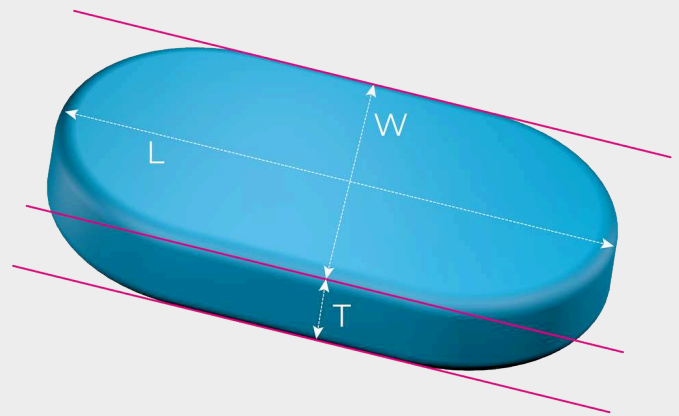

Thus, for particles with three different dimensions (e. g. almonds), the size distributions of all three dimensions can be output separately.

3D Analysis is particularly advantageous for particles that are supposed to have a specific shape like spheres, rods (extrudates), lenses or ellipsoids (“rugby-ball”-shape). With the 3D tracking technology, each particle inevitably shows a wide variety of projections, which automatically also opens new possibilities in shape analysis.

3D BEATS 2D

NEW POSSIBILITIES IN SHAPE ANALYSIS

In contrast, traditional 2D analysis captures only one image per particle in random orientation, even if the particle is measured multiple times at increased acquisition rate, there is no “mapping” of one image to another. Each individual image is treated as a new, independent measurement event. The true length, width, thickness, and shape is obscured by this. Rather, the “length” measured in 2D mode is a mixture between true 3D length and true 3D width; the “width” measured in 2D mode is a mixture between true 3D width and true 3D thickness. Only if the particles can be mechanically aligned, meaningful results are obtained in 2D mode. In the past, however, this was only feasible for some special particle shapes like cylinders.

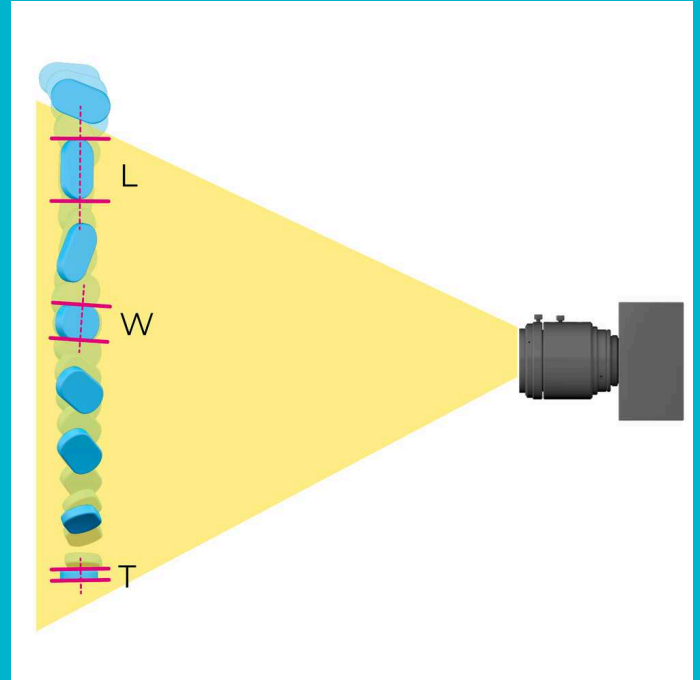

Measurement in 2D Mode

- | Particle size & shape measurement in random orientation
- | Suitable for irregularly shaped material, natural products
- | Results compatible with sieve analysis

Measurement in 3D Mode

- | Separate distribution of length, width, and thickness
- | Excellent detection of defective particles
- | More accurate volume calculation

PARTICLE SIZE AND SHAPE ANALYZER CAMSIZER 3D

EXTREMELY WIDE MEASURING RANGE WITH DUAL CAMERA TECHNOLOGY

Microtrac's unique dual camera technology is a landmark in the development of Dynamic Image Analysis. By simultaneously employing two cameras with different magnifications, extremely wide dynamic measuring ranges are achieved. This is accomplished without hardware adjustments or modifications and without compromising the accuracy.

Each camera is specialized for one size range. The ZOOM camera analyzes fine particles with highest resolution whereas the BASIC camera detects the larger particles with excellent statistics. A special algorithm combines the information provided by both cameras, covering a size range of more than three orders of magnitude.

This arrangement resolves a significant drawback of many image analysis systems that employ only one camera, e. g. microscopes. Such instruments either cannot correctly report the fine particles in wide size distributions, or the large particles are not captured reliably due to the small field of view.



- | 9 megapixel ZOOM camera
- | 5 megapixel BASIC camera
- | Calibration within a few seconds with certified reference objects
- | Wide measuring range without hardware adjustment
- | Non-contact and non-destructive measurement
- | Dust protected housing
- | Rugged construction for use in production environments
- | Automatic dust extraction in the measurement chamber to protect the user and the instrument

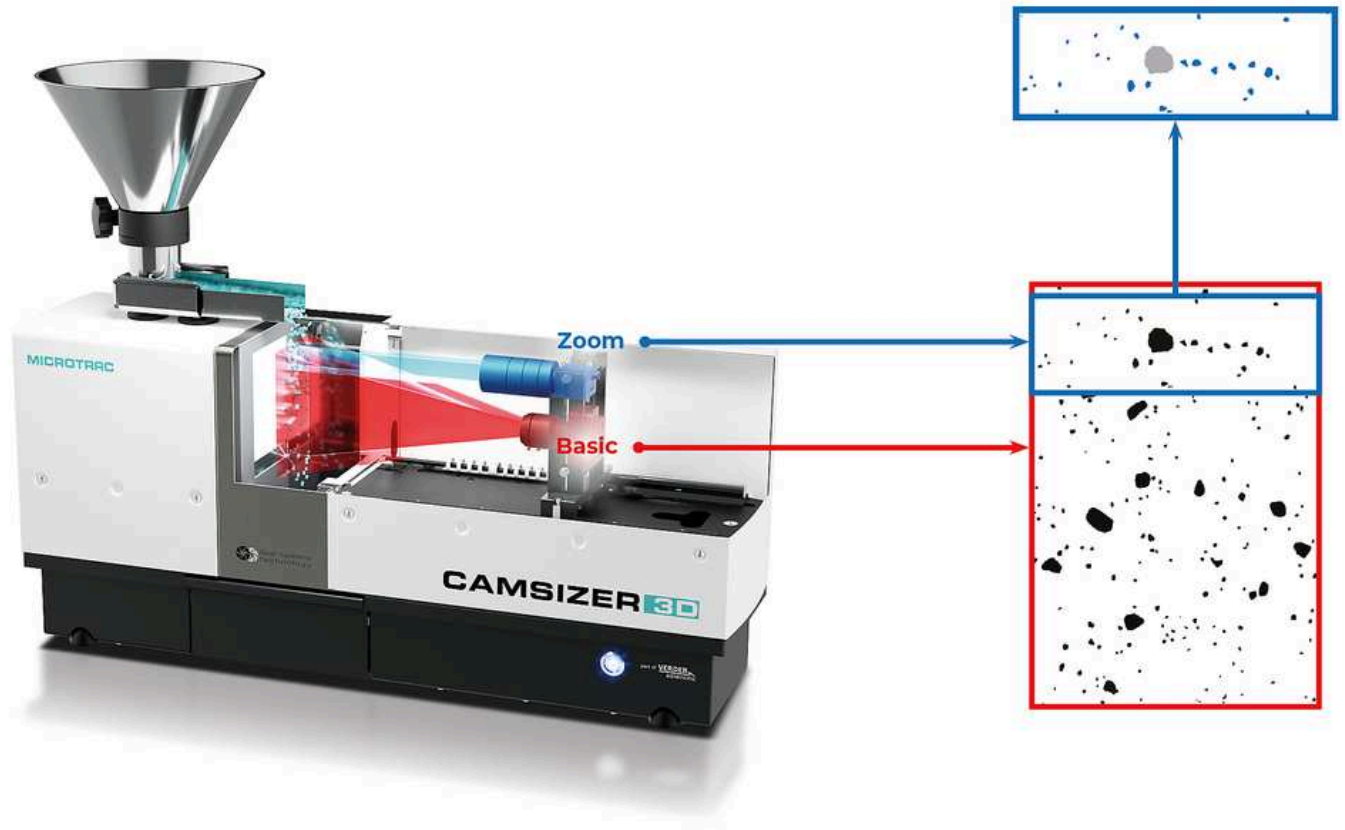

BETTER THAN EVER BEFORE

Compared to previous CAMSIZER models the CAMSIZER 3D features a significantly higher camera resolution and frame rate by employing a ZOOM camera with 9 megapixels and a BASIC camera with 5 megapixels at a frame rate of up to 250 fps.

This allows superior image quality and particle detection, for all coarse and fine samples. Broad and narrow distributions are measured with the same accuracy and precision.

The image width of the ZOOM camera is the same as that of the BASIC camera, which ensures excellent reproducibility of the measurement results within a short measurement time.



REVIEWS FROM OUR CUSTOMERS

"I am truly amazed by the CAMSIZER's ability to accurately measure the material."

Stan Kolakowski
Covia Corp

"I highly recommend for any and all particle size and shape analysis."

Allison Denton
W. R. Grace

"This product covers a very important area in materials analysis. Measurements are simple to make."

Paolo Plescia
Consiglio Nazionale delle Ricerche

Trusted reviews provided by

SelectScience®
The Fastest Way to Expert Opinion

FASTER, MORE PRECISE AND ADDITIONAL INFORMATION

CAMSIZER REPLACES SIEVE ANALYSIS

Traditional sieve analysis frequently forms the basis for quality standards and product specifications between suppliers and customers. A rapid and efficient alternative like Microtrac's CAMSIZER systems must take this into account and be able to produce results that are fully comparable.

This is why the CAMSIZER software is provided with algorithms for emulating sieving processes.

In this way many users have been able to **replace time-consuming sieve analysis** by using the CAMSIZER **without having to sacrifice the familiar quality specifications**. The automated and wear-free measurement means that the results obtained are more reliable and reproducible over time.

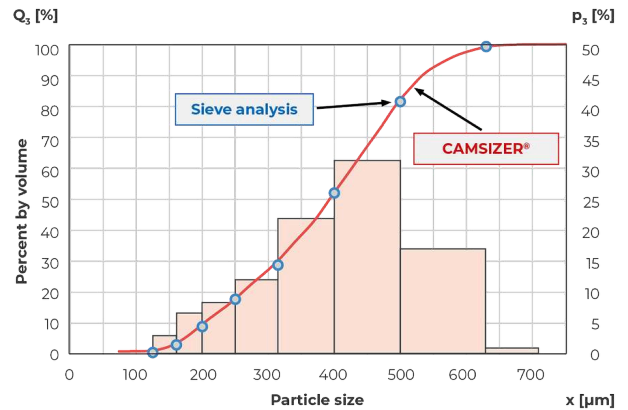

Perfect compliance of sieve analysis and CAMSIZER measurement results for granulated fertilizer

PARTICLE SIZE AND SHAPE ANALYZER CAMSIZER 3D

ACCESSORIES AND OPTIONS

Microtrac offers various sets of feed hoppers and chutes for specific applications. With the help of the feed guides, the sample stream can be oriented in a way that, for example, longish particles like extrudates are always measured in the correct orientation.



Calibration Reticle

A certified reference object is available for the CAMSIZER 3D, which allows the user to calibrate the device in a few seconds. This object is a glass pane that is inserted precisely into the measuring zone. Circles of various sizes are lithographically applied to the calibration reticle. The reproduction scale of the cameras is determined by measuring the circles. After completion of the calibration process, a protocol can be printed to document

the proper condition of the CAMSIZER 3D.



Feeder and Funnel Kits

Different chutes and funnel sets are available for the CAMSIZER 3D, which are suitable for different sample volumes and particle size ranges. In 3D mode, the width of the feeder has an influence on the number of particle images in the 3D tracks, as narrower chutes enable a higher acquisition rate due to the reduced image size. However, the use of narrow chute increases the measurement time. MICROTRAC will be happy to advise you on the selection of the most suitable configuration for your application.

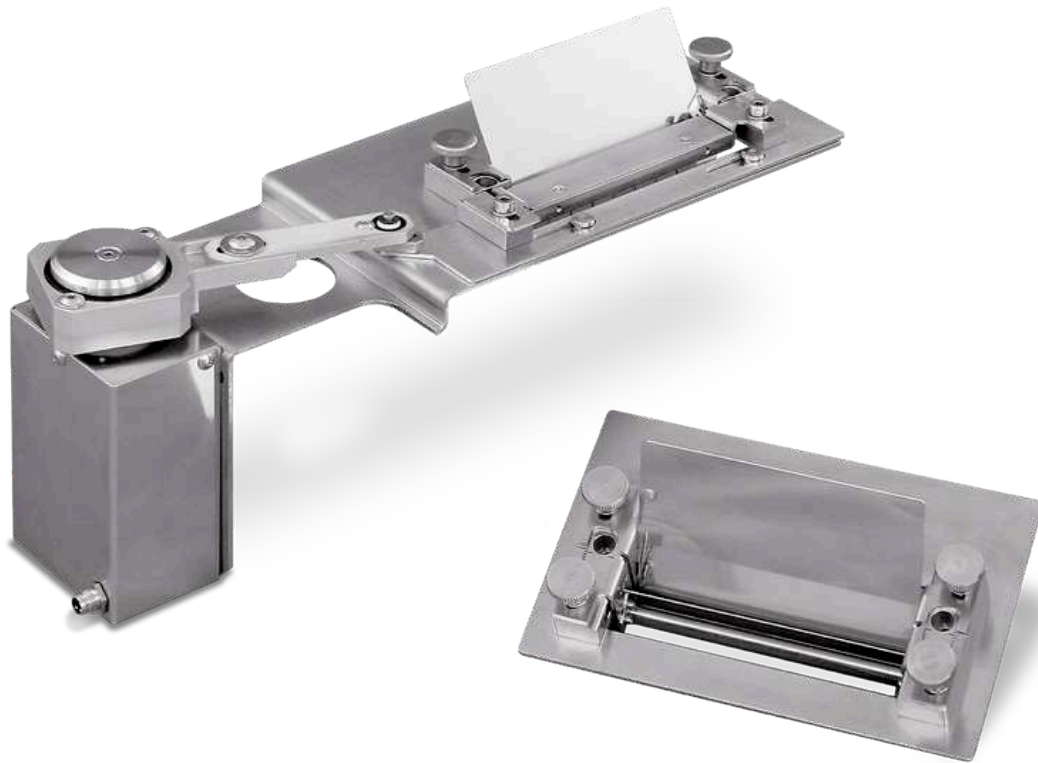

Guidance Sheets

The guidance sheet channels the sample flow before it enters the measurement zone. This can be advantageous, for example, when particles jump on the feeder. The long shield prevents the particles from being hurled over the measuring shaft and directs them into the focal plane. The guidance sheet also provides protection from air currents that could cause unwanted turbulence in the measurement zone.



Audit Trail Manager

The Audit Trail Manager is a software package that enables operation in accordance with the specifications of the 21 CFR part 11. This standard is particularly relevant in the pharmaceutical industry and its suppliers. The program option offers extensive user administration with various access levels and logs all processes in an encrypted database, the Audit Trail. Measurement results can be electronically signed for quality assurance.



Sample Splitters

Every measurement is only as good as the sampling and sample preparation that preceded it. Especially in the case of flowable bulk materials with a wide size distribution, segregation occurs, which leads to an incorrect distribution of particle sizes in the sample aliquot. By using a sample divider, representative partial samples can be generated in a simple way, which guarantee a meaningful result. MICROTRAC strongly recommends corrugated dividers and rotary sample dividers from RETSCH, also part of the Verder Scientific Group.

THE PERFECT SOLUTION FOR BUSY LABORATORIES

AUTOSAMPLER FOR BATCH PROCESSING

The Autosampler is a fully automatic sample feeding system for the CAMSIZER 3D which can be easily retrofitted to existing instruments.

It processes up to 14 samples (extendable to 40 samples or more) in a row without the need for the operator's intervention. The correct measurement settings can be read from the barcodes on the sample beaker. The Autosampler is suitable for continuous operation and allows effortlessly measuring more than 150 samples per day, even by untrained operators.

Typical applications for the CAMSIZER 3D Autosampler system include sand, superabsorbent polymers, rice, coke, tea, rubber granules, EPS, sugar, glass beads, salt, and many more.



[Click to view video](#)

PARTICLE SIZE AND SHAPE ANALYZER CAMSIZER 3D

TYPICAL APPLICATIONS

Many properties of bulk materials, like flowability, solubility, filtration efficiency, reactivity, abrasiveness, and taste, are significantly influenced by particle size. Therefore, particle size determination is commonly used as a part of quality control in many different industries.

Especially when products with specific geometry are produced, such as extrudates, abrasives, pharmaceutical pellets or fertilizer granules, shape analysis with the CAMSIZER 3D provides important measurement data determining the quality of the sample within a few minutes. Another advantage is that the method can be largely automated via automatic sample feeding systems or online connection.



sand



pharmaceuticals



sugar

- | abrasives
- | activated carbon
- | building materials
- | catalysts
- | chemicals
- | coal / coke
- | sand / gravel

- | extrudates
- | fertilizers
- | foodstuffs
- | glass / glass beads
- | pharmaceutical pellets
- | polymers
- | superabsorbents

- | refractory products
- | salt
- | sugar
- | supporting agents (proppants)
- | wood chips
- ... and many more!

APPLICATION EXAMPLES

PRECISE LENGTH MEASUREMENT

EXTRUDATES

With the patented 3D particle measurement, the length distribution of extrudates can be determined accurately. A rod-shaped ceramic extrudate with a length of 6-8 mm was measured in 3D mode, in 2D mode and with a caliper. The result shows that the 3D length corresponds to the result of the caliper, but the 2D length gives a distribution that is “too short”. Thus, the 3D image analysis is as accurate as the caliper measurement but characterizes a significantly larger number of particles in a fraction of the time.

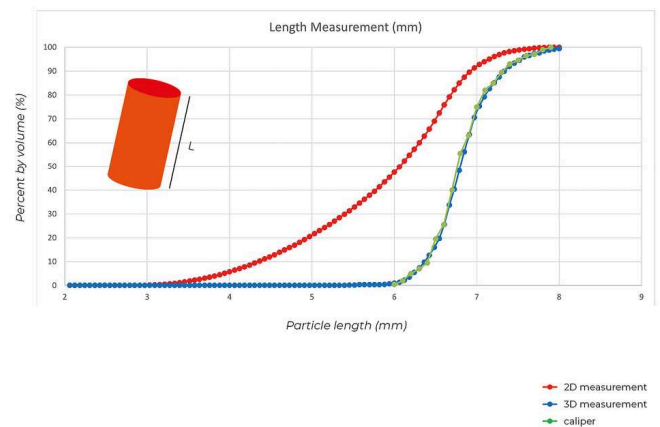

IDENTIFICATION OF DEFECTIVE PARTICLES

FERTILIZER

Particle size and shape are important parameters for the quality of fertilizers. During the granulation process the pellets will be shaped as nearly spherical particles. A non-optimal process will first be recognized by a change in particle shape as the granulate will be ellipsoidal rather than spherical. The diameter will stay the same and it will not be reported in the standard sieve analysis. By measuring the roundness and aspect ratio the CAMSIZER 3D will detect even the smallest changes in product quality.

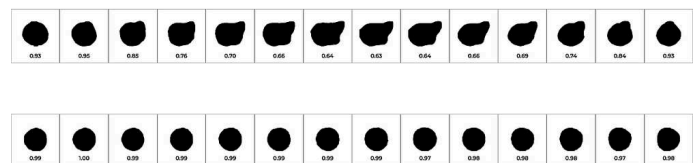

Top: Non-spherical fertilizer pellet showing true

shape on several images of the track, but also some circular projections.

Bottom: Spherical fertilizer pellets: Circular projection on every image of the 3D track.

THE POWER OF 3D ANALYSIS

COFFEE BEANS

Many natural or man-made particles have three clearly distinguishable main axes. These include extrudates, pellets, or even almonds and coffee beans. The example shows the comparison of the length, width, and thickness measurement of a sample of coffee beans. For each size definition, the correct distribution is displayed. In comparison, the 2D length measurement is “too short” and the 2D width measurement is a mixture of the true thickness and true width. Consequently, the true thickness / length ratio of the 3D measurement is smaller and more narrowly distributed than the aspect ratio in the 2D analysis.

Particle size distribution of a sample of coffee beans: 2D width (grey), 2D length (grey), 3D thickness (green), 3D width (red), 3D length (blue)

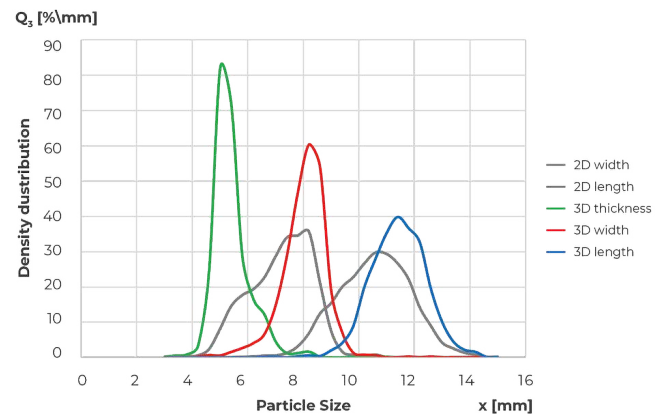

CAMSIZER 3D REPLACES SIEVE ANALYSIS

SUPERABSORBENT POLYMERS

Superabsorbent polymers can absorb large amounts of a liquid relative to their own mass. They are used in granular form, for example in baby diapers as a drying agent. Particle size is an essential quality criterion with a distribution that is usually between 100 µm and 1000 µm. Small particle size equals high specific surface area, hence faster liquid absorption. The specifications are typically based on classic sieve analyses. The CAMSIZER 3D delivers 100 % equivalent results and can fully replace this established but time-consuming and error-prone technique.



Example image of Superabsorbent Polymers (SAP)

SHAPE ANALYSIS OF REFLECTIVE BEADS

GLASS BEADS

Glass beads are used, for example, in road markings to ensure traffic safety using high retro-reflectivity beads. Fused or deformed beads reduce the reflectivity, thus harming the product quality. The CAMSIZER 3D can measure the percentage of defective beads with better accuracy than conventional 2D detection because 2D only measures one random orientation, in which the true morphology of the particle can be obscured. The graph shows the distribution of the aspect ratio of a glass sample in 2D mode and in 3D mode. In the 3D measurement, more elongated particles are detected because each glass bead is examined from different angles which leads to a difference of 17% in this case.

The 3D track shows two fused beads with an aspect ratio between 0.82 and 0.35 depending on the orientation. 3D analysis detects the true shape of particles from multiple projections and allows more accurate shape analysis.

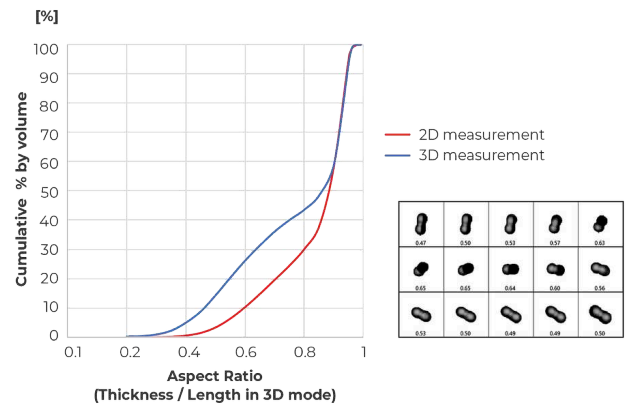

HIGH RESOLUTION SIZE MEASUREMENT

PHARMACEUTICAL GRANULES & PELLETS

The CAMSIZER 3D is ideally suited to characterize the growth of granules and pellets, i.e. in a granulation process. The results provide information about the thickness and homogeneity of coatings, dust fractions or oversized particles (agglomerates). This information is the basis for the prediction of such complex parameters as the release rate of an active pharmaceutical ingredient (API) from the granule in the human body. The example shows the initial material (green) and four coating steps (two repeated measurements for each). Even the last process step with a coating thickness of only 2.5 μm

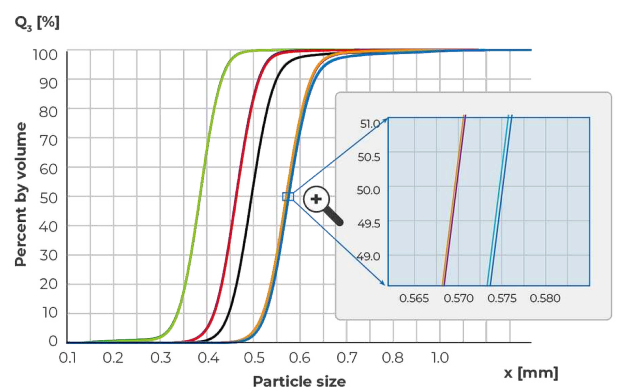

EVERYTHING IN VIEW FROM START TO FINISH

DIMENSIONS SOFTWARE

All parameters at a glance: Dynamic Digital Image Analysis provides a wealth of information about the sample material at hand. The powerful DIMENSIONS software records dozens of parameters on each individual particle and presents the results in a clear, standard-compliant measurement report that can be adapted to individual needs.

- | Intuitive operation
- | Clear arrangement of workspaces
- | User-defined report templates
- | Comparison of measurement results at a glance
- | Newly designed "Particle Viewer" workspace
- | Consistent measurement conditions through SOPs
- | Automatic testing of product specifications
- | Different user levels
- | LIMS connection
- | 21 CFR part 11 compatible version available
- | Advanced 4th generation sieve correlation algorithm

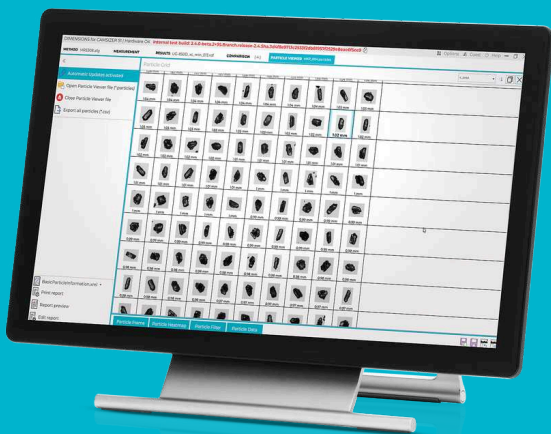

PARTICLE SIZE AND SHAPE ANALYZER CAMSIZER 3D

TECHNICAL DATA

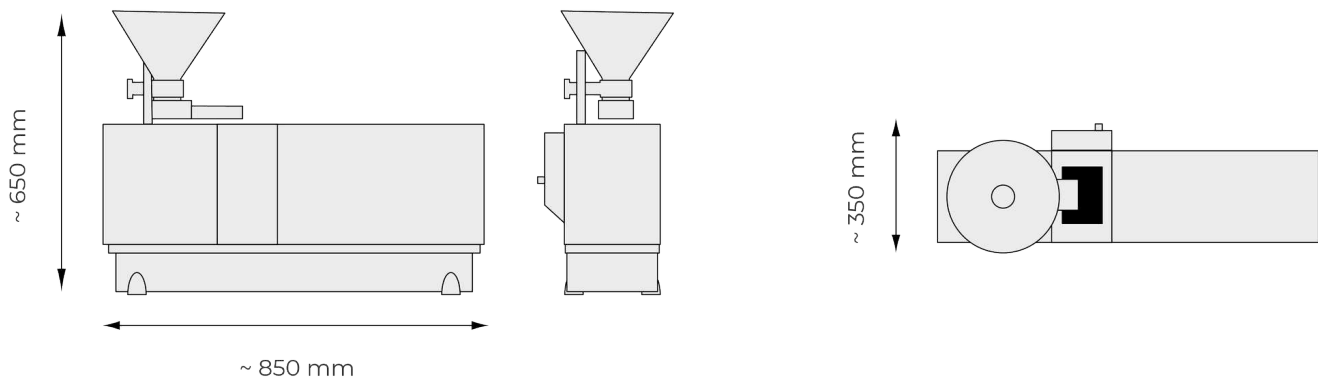

Measuring principle	2D and 3D Dynamic Image Analysis according to ISO 13322-2
Measuring range	recommended range 20 µm to 30 mm (with no hardware adjustment)
Parameter(s)	particle size, shape, volume, density, transparency and number
Camera	Dual Camera Technology, 9 MP + 5 MP; up to 250 images per second
Measurement time	approx. 2 to 5 min (depends on required measurement statistics)
Software	Microtrac DIMENSIONS
Dimensions	850 × 650 × 350 mm
Weight	approx. 40 kg
CE certified	yes

AUTOSAMPLER

Compressed air supply	6 to 8 bar
Compressed air consumption	max. 10 l/min
Dimensions	approx. 1450 x 900 x 490 mm
Weight	approx. 60 kg
Sample feed	14 samples can be placed on the conveyor belt simultaneously (opt. up to 40 samples); continuous (and unattended) operation possible; sample feed by electro-pneumatic robot arm; emergency stop-button

www.microtrac.com/camsizer-3d